

Grigsby-Grunow Co.

Model: 90

Chassis:

Year: Pre 1932

Power:

Circuit:

IF:

Tubes:

Bands:

Resources

[Riders Volume 1 - MAJESTIC 1-11](#)

[Riders Volume 1 - MAJESTIC 1-12](#)

GRIGSBY - GRUNOW CO.

MODEL 90,100
Schematic

SCHEMATIC DIAGRAM FOR MODEL 90 MAJESTIC RECEIVER

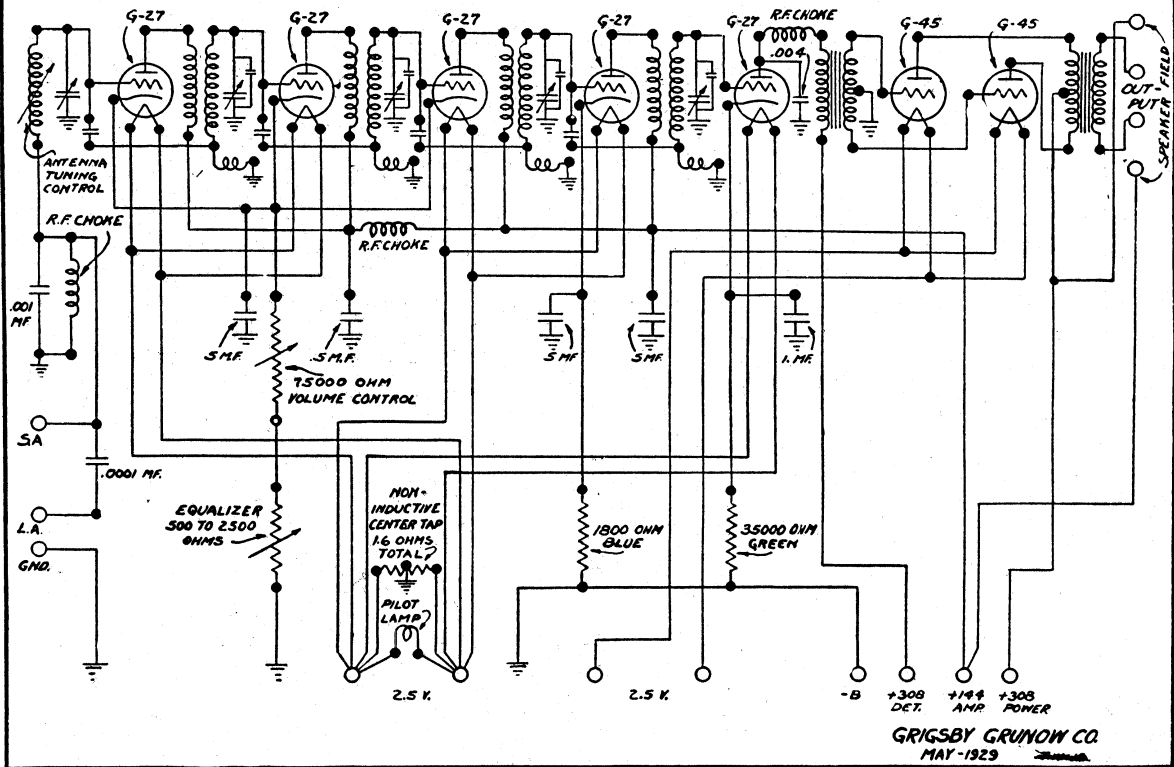

SCHEMATIC DIAGRAM FOR MODEL 100 MAJESTIC RECEIVER

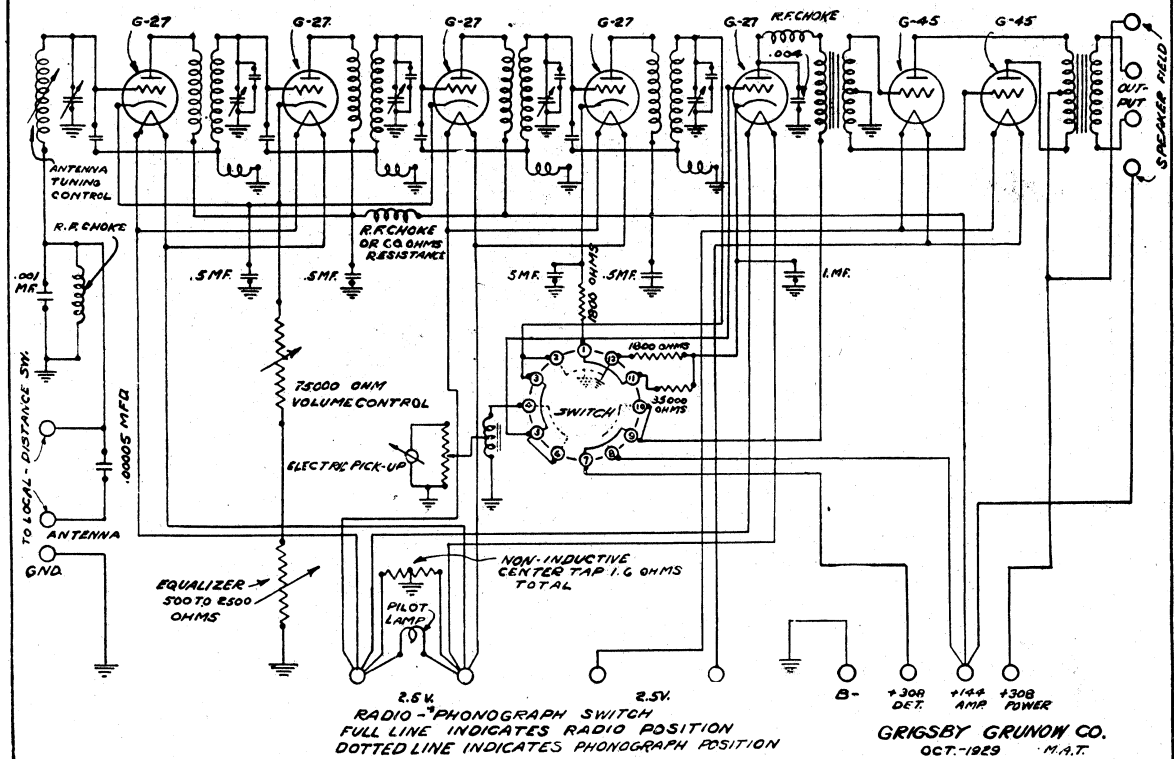

MODEL 90-B
MODEL 100-B

GRIGSBY - GRUNOW CO.

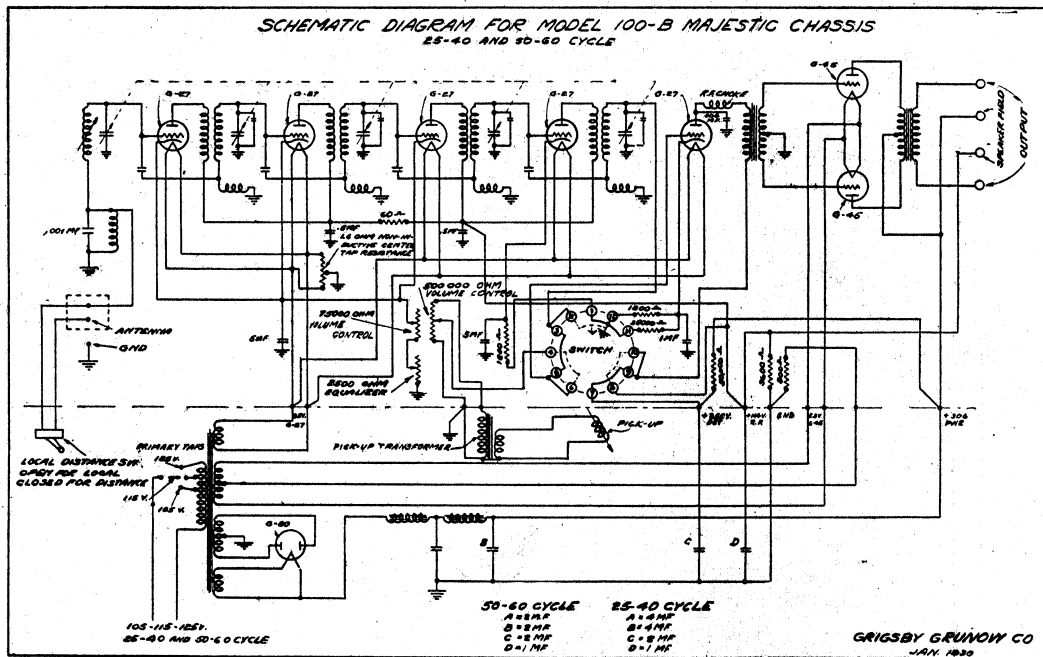
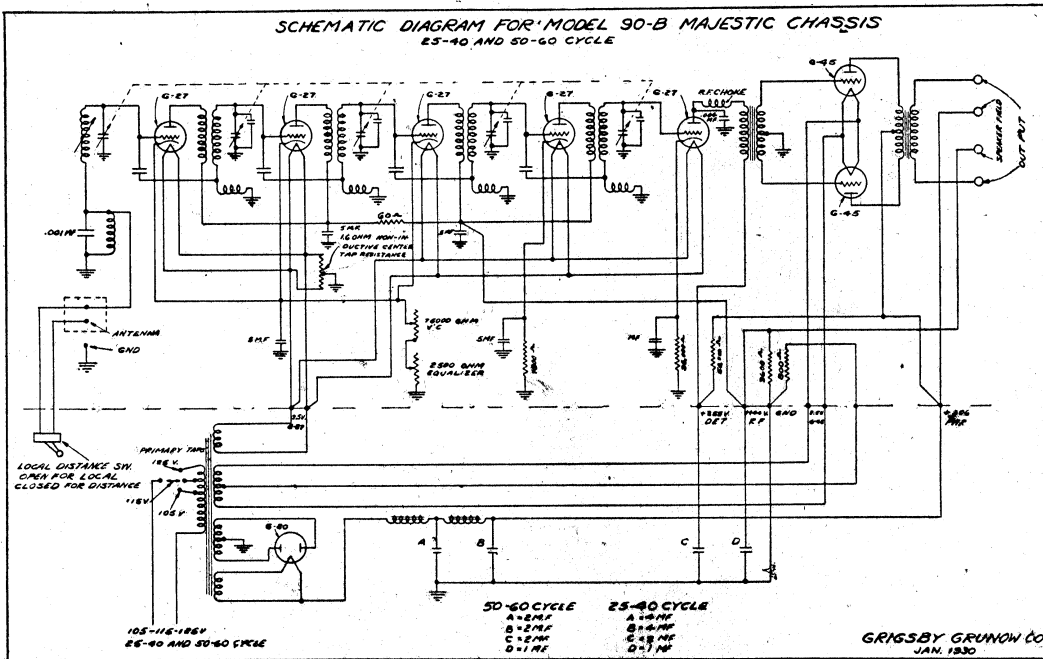

Line Voltage 112—Set on *Volt Tap—Volume Control
Position Full On
*Voltage Regulator Is Used

Models Majestic 90, 91, 92, 101 (1929)

TUBE NO. IN ORDER	TYPE OF TUBE	POSITION OF TUBE 1ST, 2ND, 3RD, 4TH, DET., ETC.	TUBE OUT					TUBE IN TESTER				
			A VOLTS	B VOLTS	A VOLTS	B VOLTS	C VOLTS	CATHODE CONTROL VOLTS	NORMAL HEATER VOLTS	PLATE M.A. TEST	PLATE M.A. CHANGE	SCREEN GRD VOLTS
1	27	1st RF	2.55	148	2.35	130	8	8	5.5	7.5	2.5	-
2	27	2nd RF	2.55	148	2.35	130	8	8	5.5	7.5	2.5	-
3	27	3rd RF	2.55	148	2.35	130	8	8	5.5	7.5	2.5	-
4	27	4th RF	2.55	148	2.35	130	9	9	5	7.2	2.2	-
5	27	Det.	2.55	306	2.35	270	30	30	1	1	1	-
6	245	Power	2.65	275	2.45	250	50	-	32	57	5	-
7	245	Power	2.65	275	2.45	250	50	-	32	57	5	-
8	380	-	-	-	-	-	-	-	100	-	-	-

